

**PARTS LIST & PART NUMBER(S) FOR STC-25 CONVEYOR**

1.	BR-3 MONORAIL	(3910-300)
2.	FRAME & LEGS	
3.	BELT RETAINER & 3a. BELT DRIVE SPROCKETS	(3910-150) & (3020-700)
4.	DRIVE SHAFT	(9510-130) 10" BELT
5.	DRIVE SHAFT SEAL KIT (2 EA. COLLARS & 2 EA. RUBBER BOOTS)	(5330-900)
6.	DRIVE CHAIN SET	(3040-250)
7.	LUBRICATING SYSTEM [FITTINGS ,TUBING ETC.]	(3110-200)
8.	ELECTRICAL CONNECTION JUNCTION BOX	
9.	WATER PRESSURE REGULATOR & GAUGE	(4810-240) & (4810-220)
10.	AUTOMATIC DETERGENT PUMP	(4420-110)
11.	MOTOR w/ COVER & SPEED REDUCER (SOLD SEPERATELY)	(CALL FOR INFO.)
12.	AUTOMATIC CHAIN TENSIONER	(3020-850)
13.	SAFETY SLIP CLUTCH	(3020-525A)
14.	SOLENOID VALVE	(4810-200)
15.	DRIVEN SPROCKET	(3020-532)
16.	PILLOW BLOCK BEARING	(3110-101)
17.	VACUUM BREAKER [SPECIFY 1/2" OR 3/8"]	(4810-600)
18.	TOP WEARBAR SYSTEM	
19.	BELT RETURN MONORAIL	(3910-300)
20.	MONORAIL MOUNTING BRACKET SPECIFY 4" OR 7" TROUGH	(3300-1321C)
21.	SLIDER PAN SUPPORT	
22.	BELT DRIP PAN	
23.	SILVER SAVER SPECIFY 10" OR 12" BELT	(3300-420) & (3300-425)
24.	DRIVE CABINET ENCLOSURE w/ DOOR SWITCH	SWITCH SAME AS #25
25.	LIMIT SWITCH	(5930-100)
26.	SLIDER PAN	
27.	LEG GUSSETS	
28.	LEG ASSEMBLY	
29.	SHELFLEX BELT [BLUE]	10" (3030-350) 12" (3030-370)
30.	DRIP TRAY	(5900-111S)
31.	SLIDER PAN TROUGH	
32.	AUTOMATIC WASH SYSTEM & TANK	SPRAY NOZZLES (4510-300)
33.	WASH TANK DOOR / SCRAP BASKET ACCESS	(5700-900) & (5700-011) 10" BELT



2081 S. HELLMAN AVE. #J ONTARIO, CALIF. 91761

(909) 947-4877 FAX (909) 947-1083

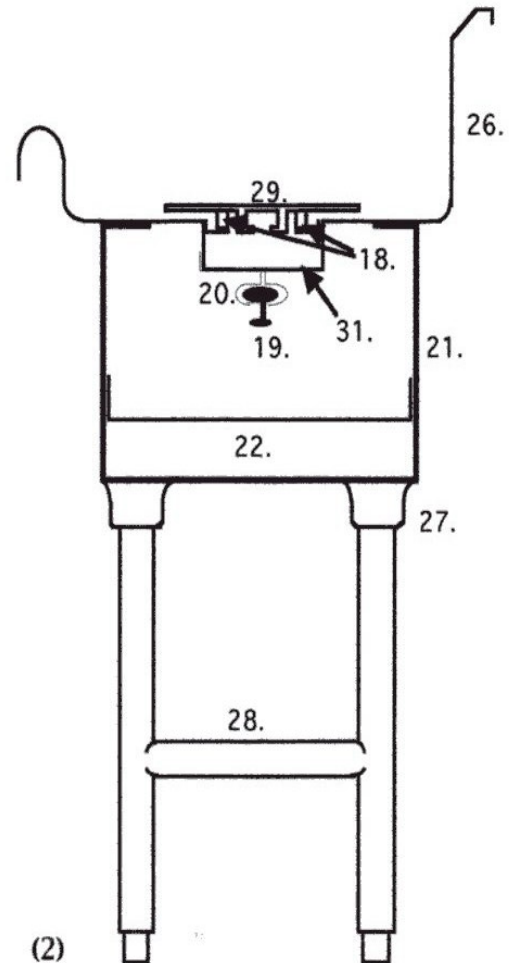

(2)